

**DISABLING AUTODOWN  
PROGRAMMABLE CORRSTACKS w/TOUCH SCREEN ONLY**

**GEO. M. MARTIN CO.**  
Serving the Corrugated  
Industry – Since 1929  
[www.geomartin.com](http://www.geomartin.com)



1250 67<sup>th</sup> Street  
Emeryville, California 94608  
TEL: (510) 652-2200  
FAX: (510) 652-6447



**NOTE: Removing Autodown is NOT a safe substitution for installing the Geo. M. Martin LCS Safety System.**

These procedures are provided to reduce the likelihood of an accident while waiting for the installation of the LCS Safety System.

The following features included in the LCS are NOT provided by simply removing the Autodown feature:

1. Without the LCS, the operator is only required to initiate the downward motion of the Stacker; once this motion begins, the operator could easily release the button and still move into the hazard area while the stacking deck is moving down. With the LCS-Manual system, the operator must hold the Deck Down Enabled button for the entire duration of the downward motion. With the LCS-Light Guard system, the light guard perimeter will stop the downward motion should the operator break the perimeter.
2. Without the LCS, the accumulator is not inhibited from cycling automatically AND is under pressure which can be released when a jam is cleared manually. With the LCS, the same mechanisms that limit the downward motion of the stacking also limit the motion of the accumulator and relieve the pressure inside the cylinders of the accumulator.
3. Without the LCS, the Auto Down Button on some of the older RDC Stackers and almost all CorrStacks is mounted directly on the end of the deck in close proximity to the hazard area. This allows the operator to activate the downward motion while in the hazard area.

## **DISABLING AUTODOWN**

### **PROGRAMMABLE CORRSTACKS w/TOUCH SCREEN ONLY**

4. Without the LCS on the stackers that do have the boom mounted controls, there is no BOOM IN POSITION sensor or OPERATOR IN POSITION sensor to make sure that A) the boom is in a position that gives the operator a view of the hazard area and B) the operator is standing in front of the boom at a safe distance from the hazard area.
5. Without the LCS, most RDC Stackers with a PLC control system have a feature known as EZ-Down, which can unexpectedly pause and then continue the lowering of the stacking deck once initiated by the operator.
6. Without the LCS, there is no redundancy in either the hydraulics or the electrical system. The basic Stacker has only a single valve holding up the Stacker with a single electrical connection. Should either item fail, it is possible for the stacking deck to lower itself without warning. This is distinct from the LCS system, in which a pair of dedicated valves (one on each cylinder) and a parallel electrical system keep the stacker in the up position.
7. Without the LCS there is no self-testing. When the LCS is first powered on, the machine requires the operator to go through about 30 seconds of self-testing procedures to make sure that all the key features of the LCS are fully functional. On a stacker with AutoDown disabled, there is no way to detect that a valve is defective until it actually fails and the deck comes down - potentially on the operator.

Technical Note: The sequence logic of the stackers is fairly complicated and major modifications are difficult without going to the full LCS solution. The process of removing Autodown essentially prevents the operator from being able to enable the Auto Down option, which is a standard feature on most stackers.

Most stackers will use the first item listed below, since the Auto/Hand selector is a physical switch. However, the Corrstack with touch control screens uses the touch screen to select Auto/Hand and thus requires a different procedure.

**DISABLING AUTODOWN**  
PROGRAMMABLE CORRSTACKS w/TOUCH SCREEN ONLY

**PROCEDURE: DISABLING AUTODOWN**

**PLEASE READ BEFORE BEGINNING THIS MODIFICATION**

**Notice – This procedure is Applicable Only to Programmable Corrstacks with touch screen-based control systems. See note 1 at the end of this document to verify which Corrstack you have.**

**Notice – Only a skilled electrician authorized by the employer should carry out this modification.**

**Caution - The machine must be in a Zero Energy State before beginning this modification. Perform the Lock-Out-Tag-Out procedures specified by the employer for this machine.**

The intent of this document is to guide the employer through the process of disconnecting the Autodown function on their MARTIN Programmable Corrstack with a touch screen-based control system. We define the term “Autodown” as a function of the stacker in which it automatically lowers after a load change. When Autodown is disabled, the stacker will lower as before; the only difference is that the Autodown push button must be pressed and held in for the deck to move.

The MARTIN Programmable Corrstack with touch screen-based control system utilizes a touch button instead of a physical selector switch to select the Down – Hand or Down – Auto mode of operation. Therefore, the procedure for disabling and operating this stacker is exclusive to this model of Corrstack.

Before we begin you will need the following materials:

1. 1 – 120vac Idec RR3B-U or equivalent relay, and appropriate base.
2. 10 feet of white, 16 gauge stranded hookup wire.
3. 20 feet of red, 16 gauge stranded hookup wire.
4. Wire markers.

**Step 1.** Follow your plant’s Lock-Out-Tag-Out procedure. Open main electrical enclosure and locate relay CR-SV. Mount the new relay on the din rail as close to CR-SV as you can get it. Label this relay CR-1

## DISABLING AUTODOWN

### PROGRAMMABLE CORRSTACKS w/TOUCH SCREEN ONLY

- Step 2. Next, connect one end of the white hookup wire to terminal A(-) of relay CR-1. Terminal A(-) should coincide with the neutral side of the relay's coil. Connect the other end of the wire to terminal X2. Figure 1 below illustrates this connection.

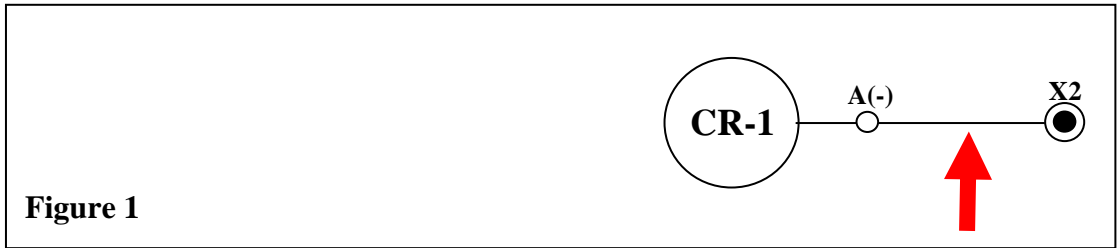

- Step 3. Connect one end of the red hookup wire to terminal B(+) of relay CR-1. Terminal B(+) should coincide with the line side of the relay's coil. Connect the other end of the wire to terminal 56. Figure 2 below illustrates this connection.

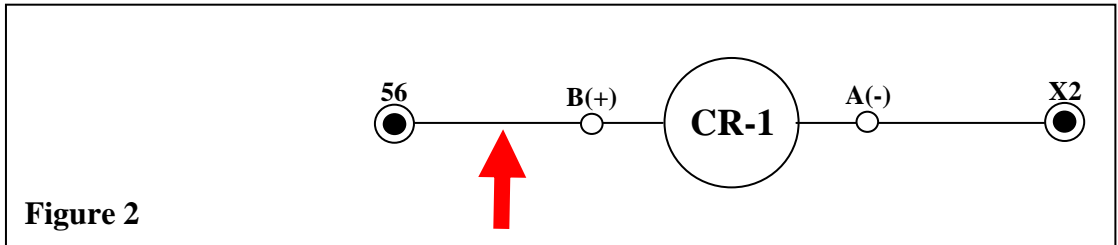

- Step 4. Locate wire #119 running to terminal 14 of relay CR-SV. If you cannot find any markings that identify this wire, mark it so that it can be reconnected in the future. Now disconnect the wire, and land it on terminal 7 of CR-1. Figure 3 below illustrates this connection.

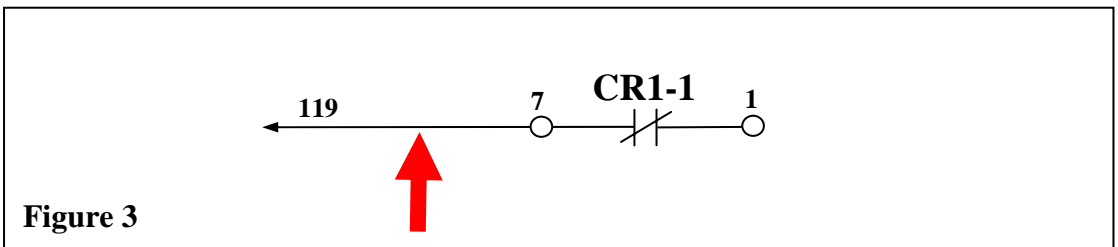

- Step 5. Use one end of the red hookup wire and mark it 119A, then connect it to terminal 1 of relay CR-1. Connect the other end of the wire to terminal 14 of relay CRSV. Figure 4 below illustrates this connection.

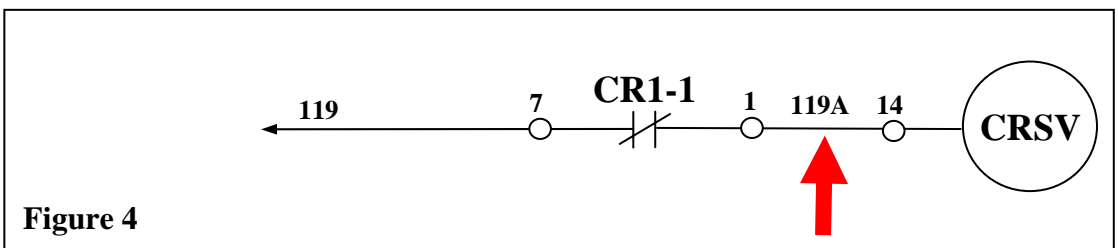

## DISABLING AUTODOWN PROGRAMMABLE CORRSTACKS w/TOUCH SCREEN ONLY

- Step 6. Use one end of the red hookup wire and mark it 57, then connect it to terminal 57. Connect the other end of the wire to terminal 4 of relay CR-1. Figure 5 below illustrates this connection.

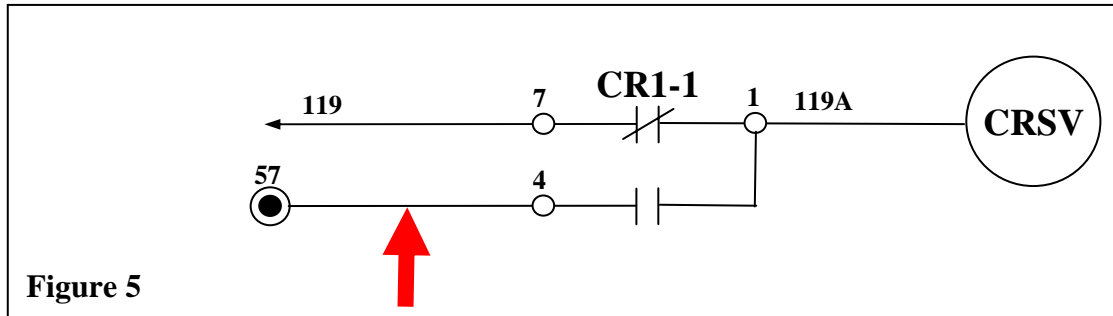

- Step 7. Restore power to the stacker, then perform the following tests to make sure the stacker will not lower automatically after a load change. First: start the stacker, ask the operator to begin stacking product, and wait for the stacker to reach the load change height. At this point the slats will rise, signifying that the stacker is ready to discharge the finished load. Once the finished load had been discharged, the stacker should wait for the operator to press and hold in the Autodown push button. The stacker should then lower all the way down. If the stacker begins to lower without pressing the Autodown push button, repeat steps 1 thru 5. If, after repeating these steps, the stacker still continues to lower automatically, consult Martin Field Services for Technical Support.

**Note 1.** This procedure is *Applicable Only* to Programmable Corrstacks with touch screen-based control systems. To determine whether you have this version of Corrstack, see the picture in Figure 6, which shows the main operator's control console and touch screen. If this picture doesn't match your machine, refer to document Doc\_000372.pdf for the correct procedures for disabling Autodown. This document can be downloaded from our website go to



<http://www.geomartin.com/safety/noautodown.htm>

**Figure 6 Programmable Corrstack  
with Touch Screen**